

Honeywell

HA60WLMZL

60 Series 1.5 NPT Longer Wall Mount for PTZ

The 60 series wall mount is compatible with the following Honeywell camera:

- HC35WZ2R25
- HC35WZ5R30
- HC35WZ5R30W
- HC60WZ2E30
- HC60WZ2R40
- HC60WZ5R30
- HC60WZ4R40WI
- HC60WZ4R40KI
- HC60WZ8R40WI
- HC60WZ8R40KI
- HC70WZ5E30

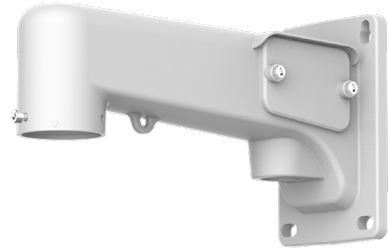

The following accessories are provided along with the package:

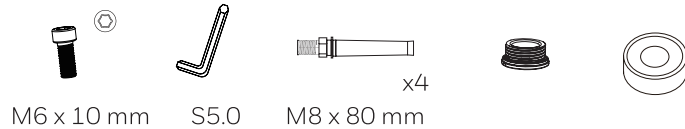

Specifications

PARAMETER	
Material	ADC12
Color	RAL 9003
Dimensions	109 mm x 164 mm x 279.3 mm (4.29" x 6.46" x 11.0")
Maximum Load Capacity	8 kg (17.6 lb)
Product Weight	0.99 kg (2.18 lb)
Package Weight	1.33 kg (2.93 lb)

Installation Notes

- Install the mount on a flat, non-textured surface.
- The surface must be capable of supporting at least three times (3x) the total weight of the camera and the mount.

Dimensions

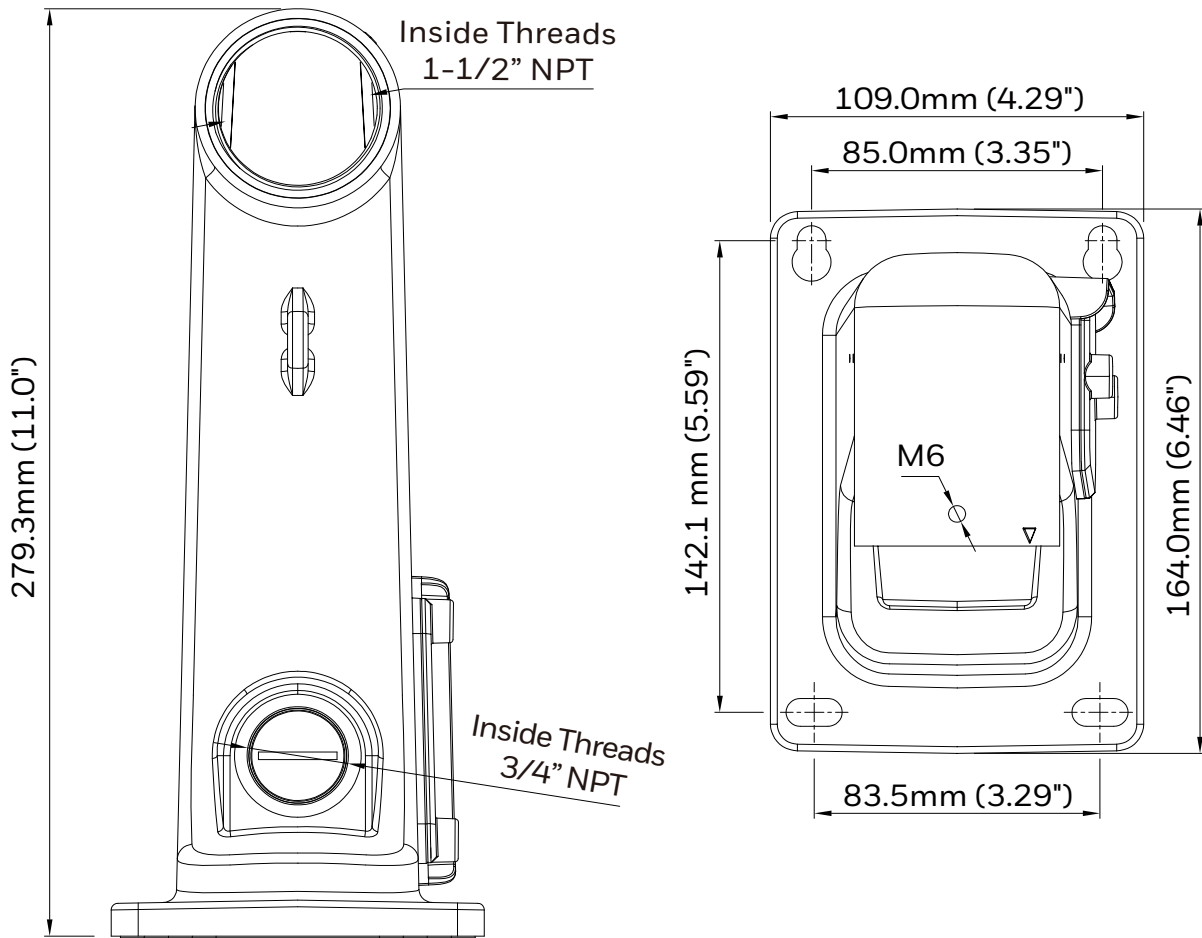

Honeywell

buildings.honeywell.com/security
+1 800 323 4576 (North America only)
Document 800-60IS17-Rev A-02/2025

© 2025 Honeywell International Inc. All rights reserved. No part of this publication may be reproduced by any means without written permission from Honeywell Video Systems. The information in this publication is believed to be accurate in all respects. However, Honeywell Video Systems cannot assume responsibility for any consequences resulting from the use thereof. The information contained herein is subject to change without notice. Revisions or new editions to this publication may be issued to incorporate such changes.